

Extruded Aluminum Damper • 6" Deep • 6" Airfoil Blades • Parallel or Opposed • Thermal Break

STANDARD CONSTRUCTION

- FRAME:** 6" deep x 1 7/8" high x .125" thick (nominal) wall thickness 6063-T52/T6 extruded aluminum, and 2 thermal breaks filled with polyurethane and debridged for thermal isolation.
- BLADES:** 6" wide x .081" thick (nominal) wall thickness 6063-T52/T6 extruded aluminum, airfoil profile injected with a two-part polyurethane (CFC free) foam, and debridged for thermal isolation.
- AXLES:** 1/2" dia. extruded aluminum "Pin-Lock" design, interlocking into blade section.
- BEARINGS:** "Double-sealed" with celcon inner bearing riding inside a polycarbonate outer bearing positively locked into frame, designed so that there shall be no metal-to-metal or metal-to-bearing riding surfaces.
- LINKAGE:** Concealed in jamb of heavy aluminum. Crank arm permanently locked to blade axle by two stainless steel fasteners. The crank arm contains a 1/2" dia. metal pivot riding in a celcon bearing. A 1/4" - 20 set screw with locking patch ties the 5/16" dia. aluminum linkage rod. The linkage of each damper is individually adjusted.
- SEALS:** Extreme low temperature seal system, extruded silicone rubber blade edge seal that fits into a ribbed groove insert in blades with an extruded polycarbonate seal at jambs.
- FINISH:** Mill.

TEMP. LIMITS: -70°F to +200°F

OPTIONS

- Hand Quadrants
- 120V, 24V Electric, or Pneumatic Actuators
- Jackshafting
- Auxiliary Switch
- Explosion Proof Housing

NOTES

1. Nominal deductions will be made to the opening size given.
2. Dampers with multiple panels in both width and height may require structural support. It is recommended that large openings be designed with structural members so that dampers will span either width or height with a single panel. Structural support will not be provided with standard dampers.
3. Not recommended for blades installed vertically.
4. Approximate shipping weight is 6.5 lbs./sq.ft.

DAMPER SIZES

Blades	Minimum Panel	Maximum Panel
Parallel	8"W x 10 7/8"H	60"W x 72"H
Opposed	8"W x 10 7/8"H	60"W x 72"H

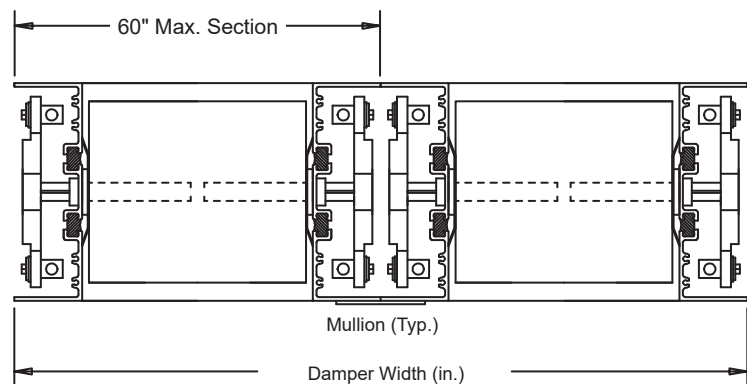
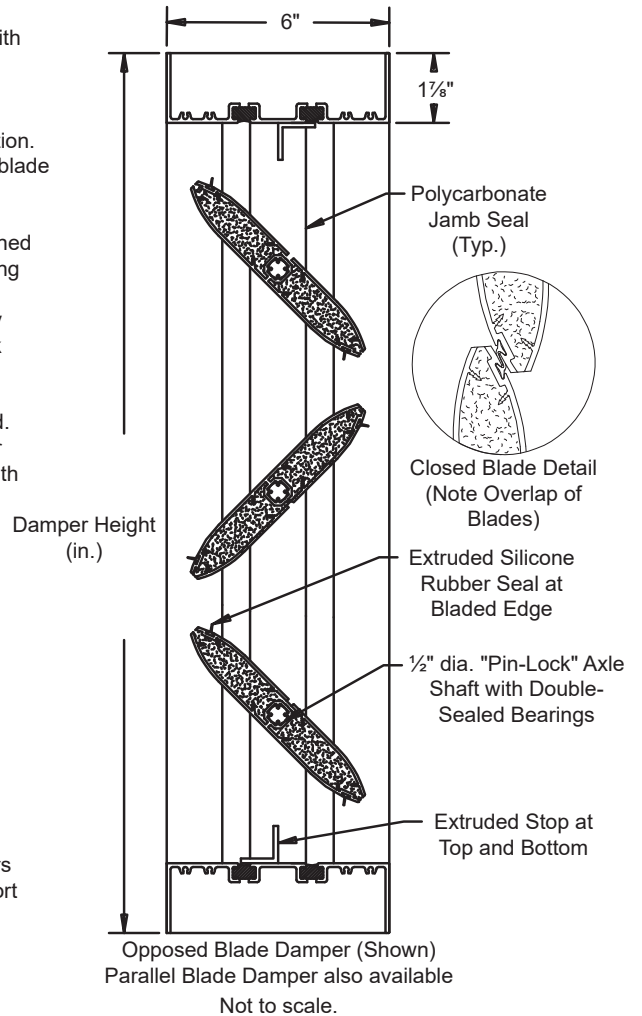

Item #	Qty	Width	Height	Blade Position		Actuator Model	Location		Function		Union Made
				Para.	Oppo.		Interior	Exterior	N.C.	N.O.	
Arch. / Eng.:						EDR:	ECN:		Job:		
Contractor:											
Project:						Date:	DWN:		DWG:		

In the interest of product development, Louvers & Dampers reserves the right to make changes without notice.



PERFORMANCE DATA

PRESSURE DROP

Model T29B Damper Size 36" x 36"

Pressure Drop Ratings are tested in accordance with AMCA Standard 500-D using test set-up Fig. 5.3 for damper installed with duct upstream and downstream. Static pressures are corrected to .075 lb/cu.ft. standard air density.

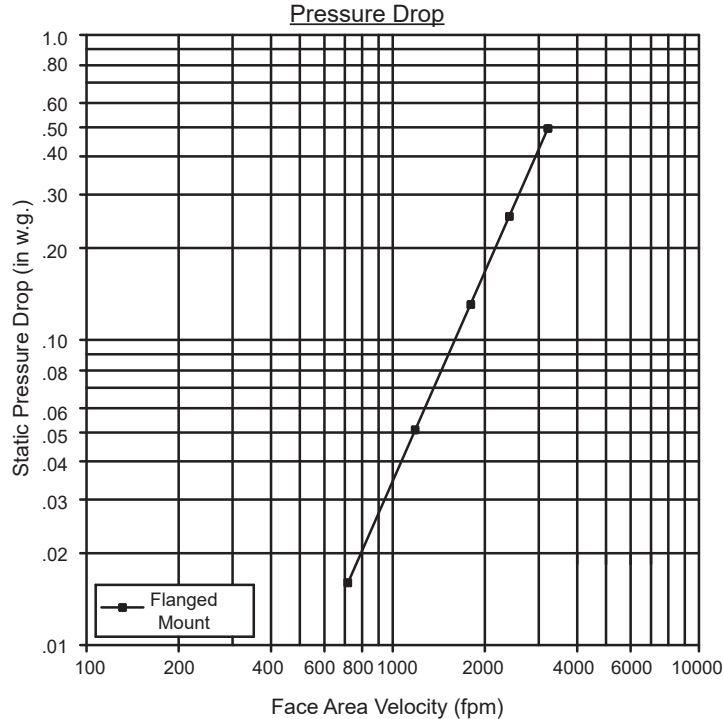

LEAKAGE

Air leakage ratings are tested in accordance with AMCA Standard 500-D using test set-up Fig. 5.4. Data is based on a closing torque of 5 in-lb/sq.ft. for dampers less than 6 sq.ft having a closing torque of 40 in-lb. Damper closing torque is applied to damper operating shaft.

Total cfm Leakage at 1 in. w.g. Static Pressure Differential

Height	Width				
	12"	24"	36"	48"	60"
12"	2	4	6	8	10
18"	3	6	9	12	15
24"	4	8	12	16	20
30"	5	10	15	20	25
36"	6	12	18	24	30
42"	7	14	21	28	35
48"	8	16	24	32	40
54"	9	18	27	36	45
60"	10	20	30	40	50
66"	11	22	33	44	55
72"	12	24	36	48	60

Leakage Correction Factor

Damper Width 12" - 60"	Static Pressure in.wg						
	2"	3"	4"	5"	6"	7"	8"
	1.44	1.64	2.00	2.22	2.44	2.54	2.82

Use of correction factors will give leakage values at greater than 1" pressures.

Model T29B Damper Limitations

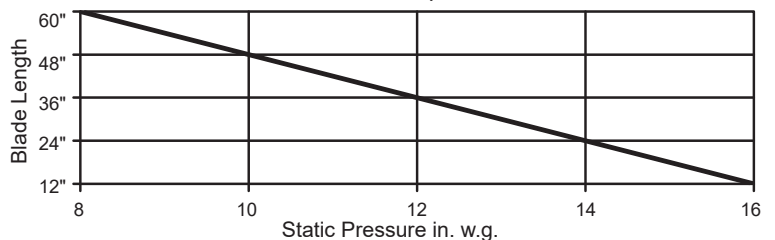

Model T29B damper design at reduced lengths can withstand higher static pressure limits without sacrificing damper operation and performance. Static pressures above 8 in. w.g. will affect operation torque value.

PERFORMANCE DATA

THERMAL PERFORMANCE

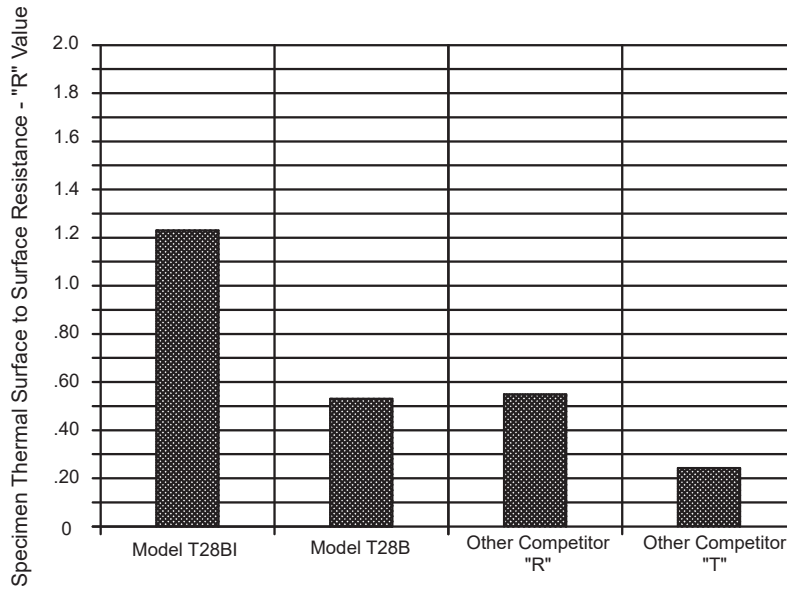

Damper Assembly Thermal Performance Rating tested to ASTM C-1363-97, Standard Test Method for Thermal Performance of Building Assemblies by Means of a Hot Box Apparatus and replaces C-236 and C-976 test methods.